

# The 2 Step.

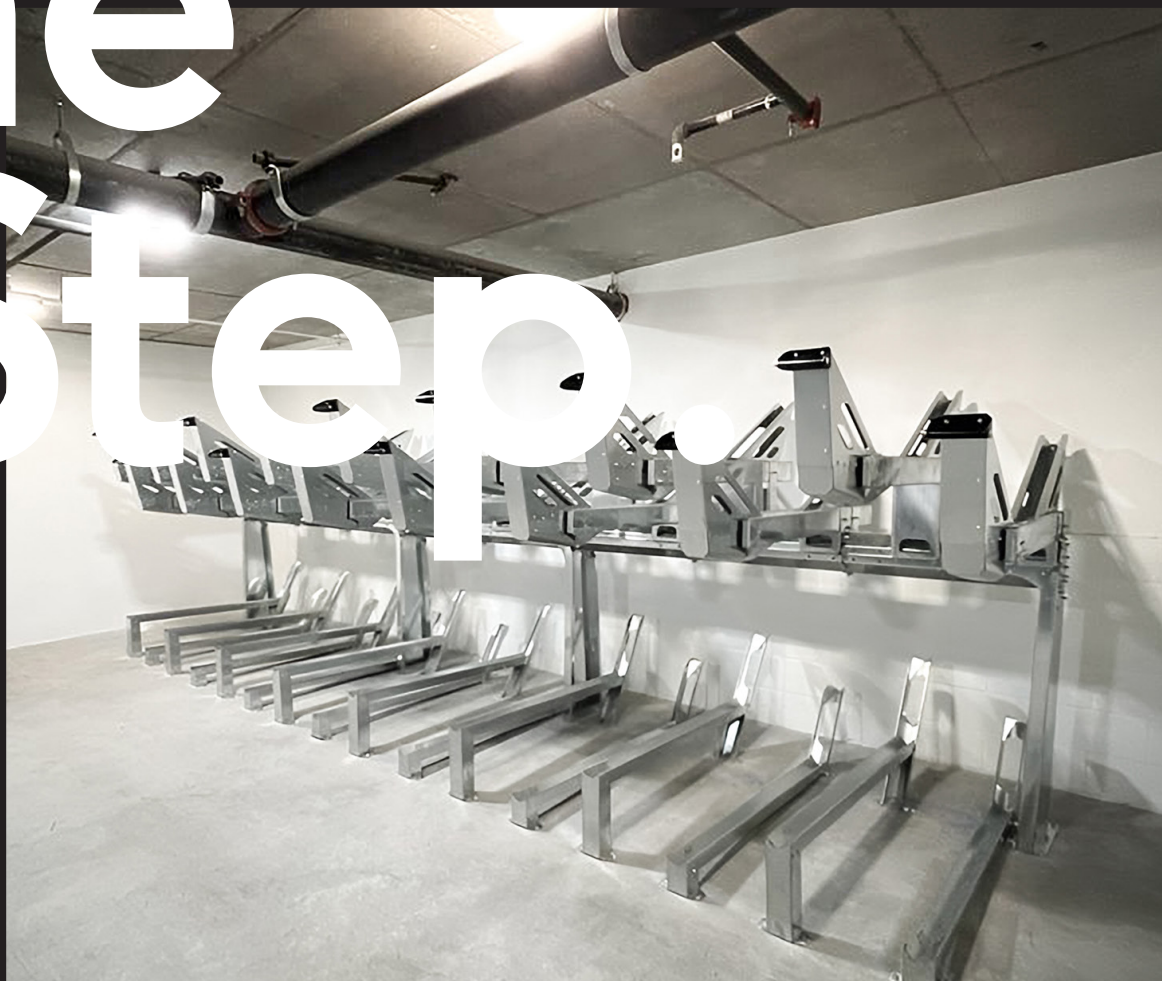

Spec Sheet

Five  
At  
Heart

# Gas assisted, security focused double tier bike parking.



Five  
At  
Heart

The logo for Five At Heart features the text "Five At Heart" in a bold, black, sans-serif font. To the right of the text is a circular graphic with five red lines radiating outwards from the center, resembling a stylized heart or a target.

# Staggered.



## Material

Hot dipped galvanised

Handle standard powder coat colour satin black (custom colours available, minimum order 20)

## Specification

### (X) Aisle

AUS Standard (2890.3) 2000mm (6'7")

### (Y) Centre Spacing

AUS Standard (2890.3) 400mm (1' 3 3/4")

Manufacturer Minimum Requirement 400mm (1' 3 3/4")

San Francisco (CA) Standard 430mm (1'5")

### (Z) Ceiling Height Minimum

AUS Standard (2890.3) 2700mm (8'10")

Manufacturer Minimum Requirement 2700mm (8'10")

TOP VIEW

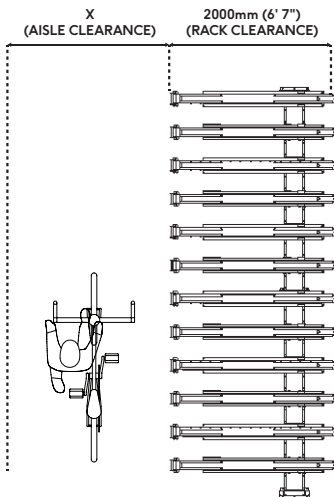

SIDE VIEW

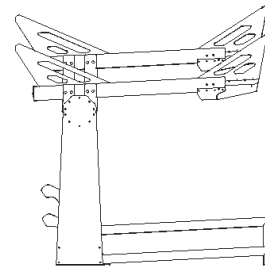

FRONT VIEW

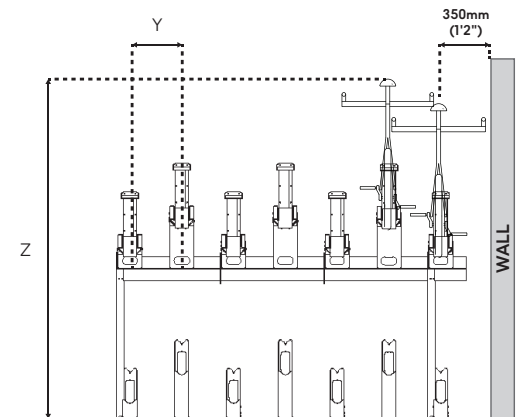

# Double Sided.

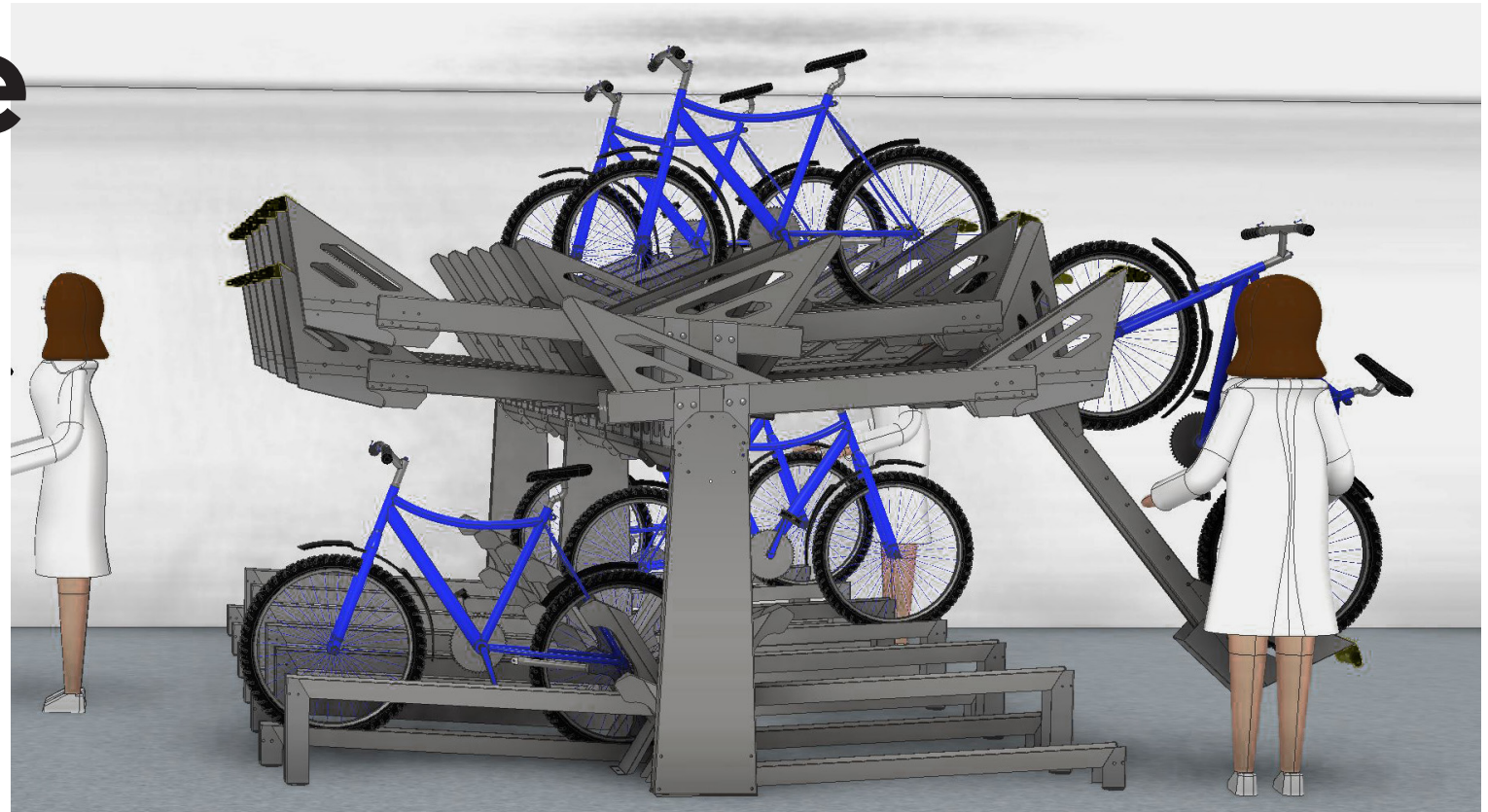

TOP VIEW

SIDE VIEW

FRONT VIEW

## Material

Hot dipped galvanised

Handle standard powder coat colour satin black (custom colours available, minimum order 20)

## Specification

### (X) Aisle

AUS Standard (2890.3) 2000mm (6'7")

### (Y) Centre Spacing

AUS Standard (2890.3) 400mm (1' 3 3/4")

Manufacturer Minimum Requirement 400mm (1' 3 3/4")

San Francisco (CA) Standard 430mm (1'5")

### (Z) Ceiling Height Minimum

AUS Standard (2890.3) 2700mm (8'10")

Manufacturer Minimum Requirement 2700mm (8'10")

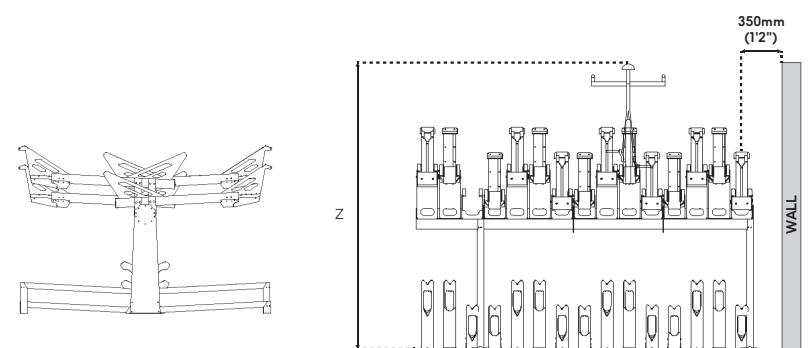
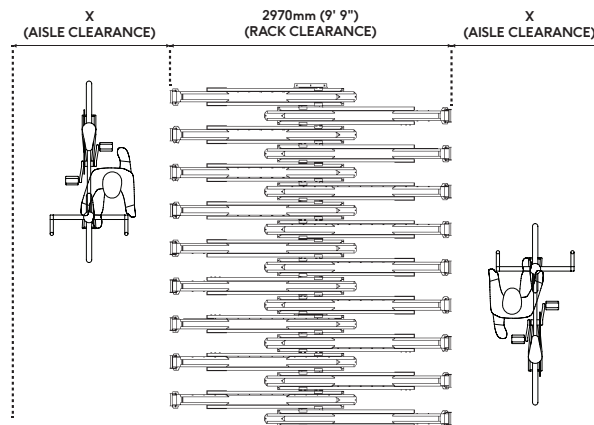

# 2 Step 1.0

ALL CONTENT REMAINS  
PROPERTY OF FIVE AT  
HEART PTY. LTD.

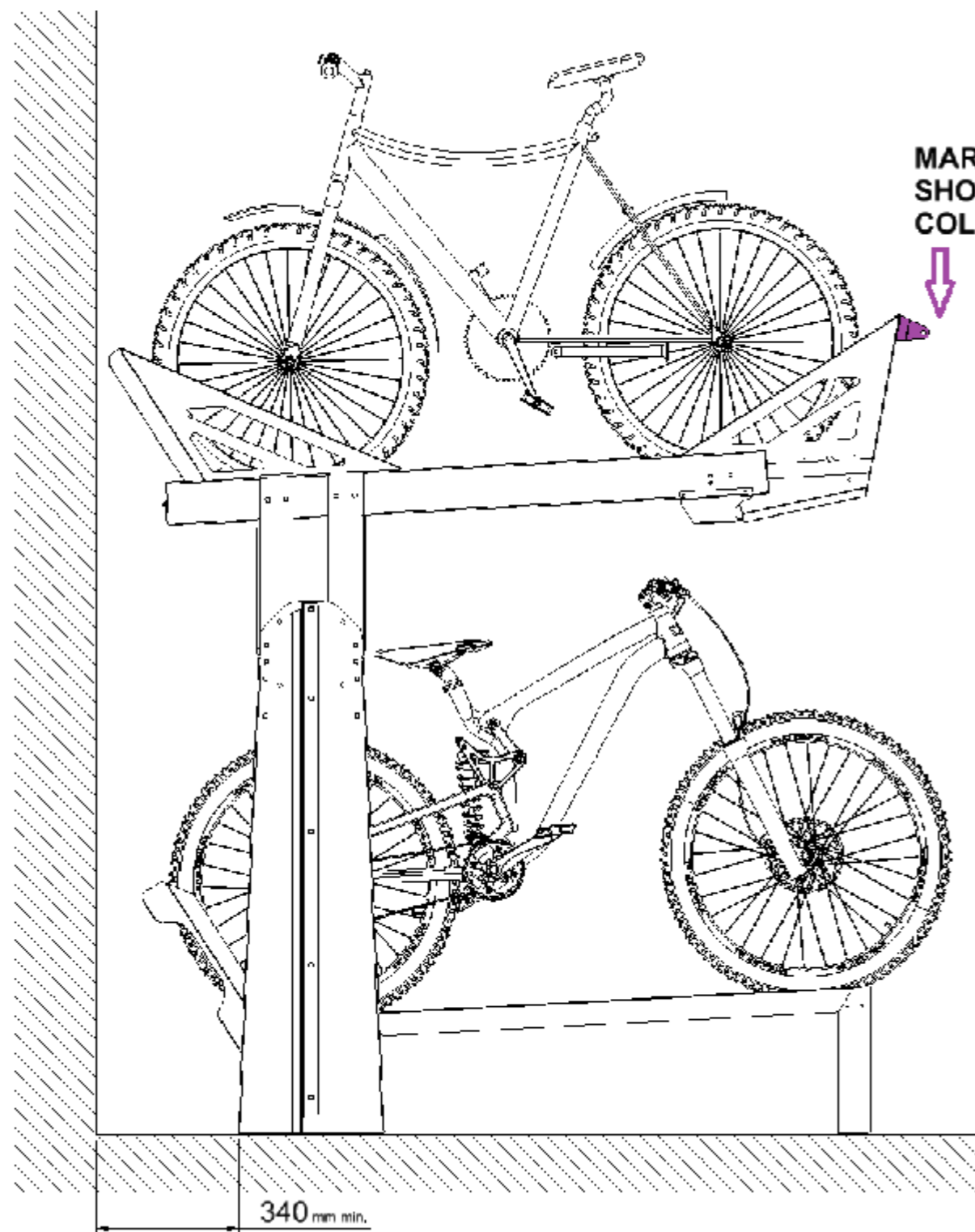

MARKED PARTS  
SHOW EXTENT OF  
COLORED POWDER COAT

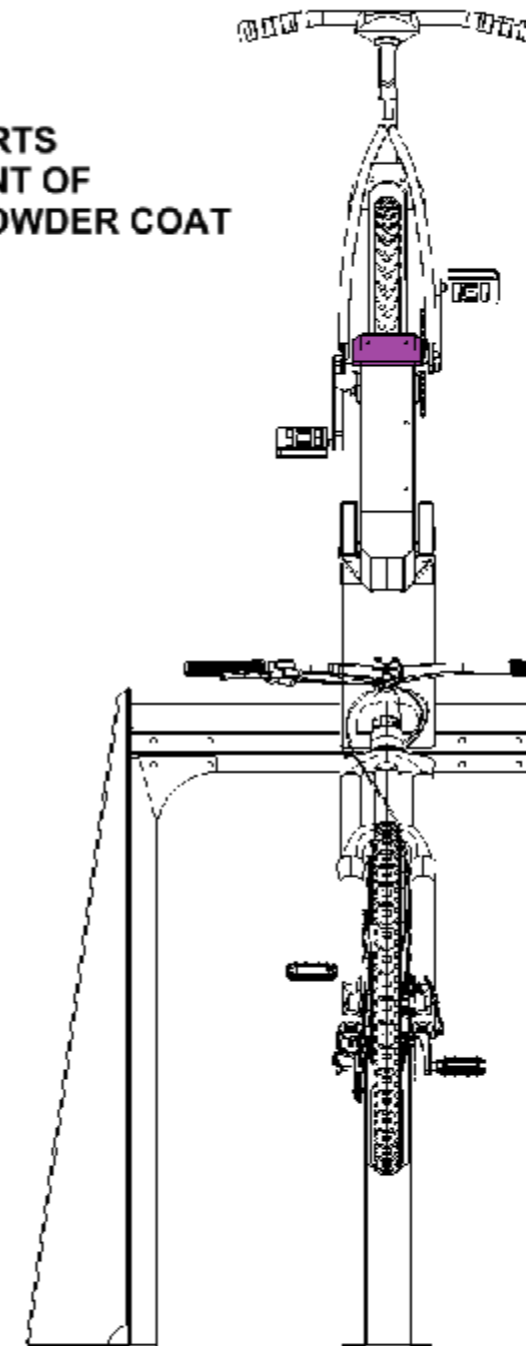

100mm FIXING DEPTH  
- TOWERS

50mm FIXING DEPTH  
- BOTTOM SPACES

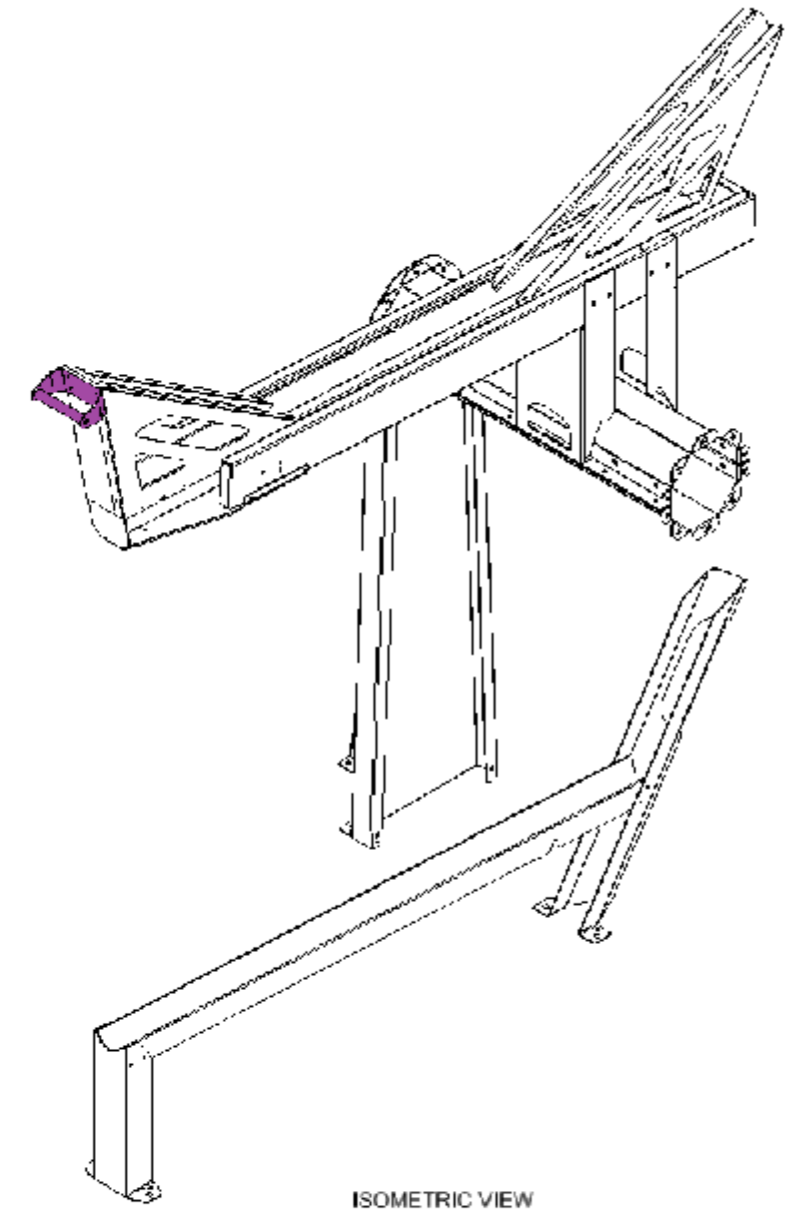

ISOMETRIC VIEW

Item	Item Description
Powder Coat Colour	Black
Floor Substrate	
Rack Substrate	Galvanised Steel

Project: \_\_\_\_\_



# 2 Step Warranty and Technical Data

## Warranty Information

Five At Heart products come with a standard 2 year warranty, effective from the handover date.

For the warranty period, we warrant that the equipment (and any materials) we supply will comply with the relevant standards at the date of installation.

This warranty is limited and may be excluded in part or in full in light of user damage or failure to install to Five At Heart specification.

We recommend a monthly visual inspection for signs of damage or need for cleaning.

Contact Five At Heart in the event of product damage.

## Fixing options / and detail

**Fig 1** M10/50mm (1 15/16") galvanised sleeve anchor

## Substrate Requirements

- Concrete – 100mm (3 15/16" ) thick and in good condition

## Maintenance Requirements

If any moving parts appear to be malfunctioning, discontinue use and contact Five At Heart.

## Cleaning

Cleaning should start at the time the products are installed, ensuring that construction materials such as concrete, plaster and paint splashes are removed before they have a chance to dry. Failure to remove these materials will require aggressive cleaning in the future, that may be harmful to the products.

Wipe with a damp cloth for surface cleaning. Regular cleaning may be done with a solution of warm water and a non-abrasive, pH neutral detergent solution. Surfaces should be thoroughly rinsed after cleaning to remove all residues.

**WARNING:** DO NOT UNDER ANY CIRCUMSTANCES USE STRONG SOLVENTS SUCH AS THINNERS OR SOLUTIONS CONTAINING CHLORINATED HYDROCARBONS, ESTERS OR KETONES. ABRASIVE CLEANERS OR CUTTING COMPOUNDS SHOULD NOT BE USED.

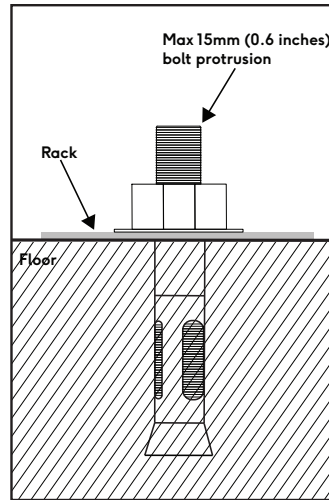

**Fig 1** M10/50mm (3/8" x 3") galvanised sleeve anchor

# Five At Heart



Creating  
spaces  
for however  
you Roll...



[fiveatheart.com](http://fiveatheart.com)

**Australia**

1300 769 332 or [au\\_info@fiveatheart.com](mailto:au_info@fiveatheart.com)

**North America**

1888 218 3433 or [na\\_info@fiveatheart.com](mailto:na_info@fiveatheart.com)

**Europe**

(+44) 20313 71966 or [eu\\_info@fiveatheart.com](mailto:eu_info@fiveatheart.com)