

┌
Seymour
Install
Guide

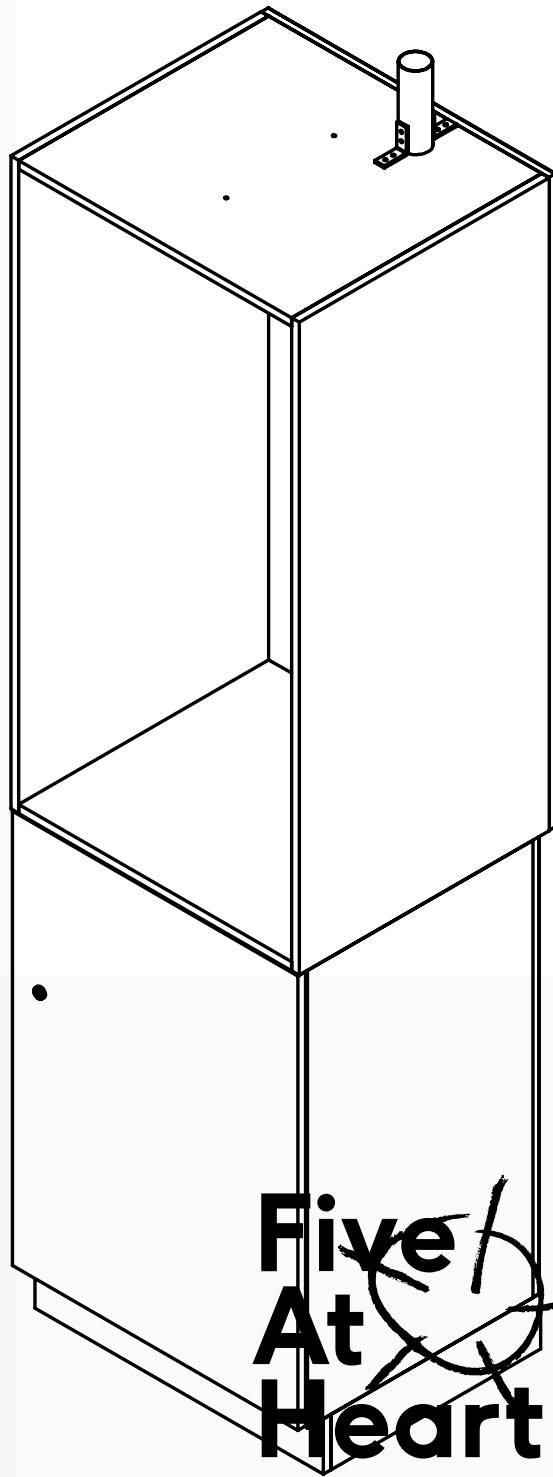

Five
At
Heart

Getting Started

1

- 2 Preface
- 2 Tools Checklist
- 2 Hardware Checklist
- 3 Components Checklist

Step By Step

2

- 3 Initial Setup
- 3 Seymour Placement
- 4 Securing Seymour
- 4 Finishing Panels
- 5 Commissioning/Troubleshooting

Preface

Welcome to the installation guide for the Seymour. To ensure a smooth and hassle free install experience please follow and read the instructions carefully.

Tools

1. Impact Driver



2. Drill

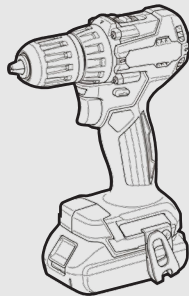

Materials/Hardware

Seymour Unit

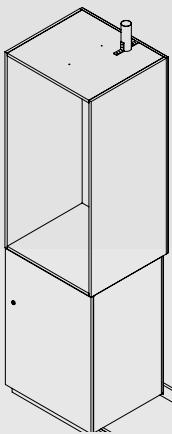

30mm Screws
Panhead



40mm Screws
Countersink



Screw Caps



Additional Items For Panels

1. Track Saw

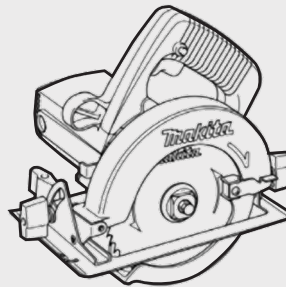

2. Planer

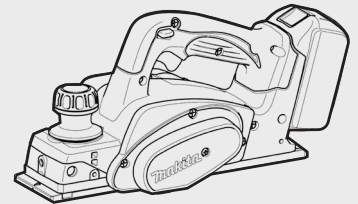

3. Measuring Tape

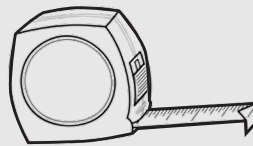

4. Permanent Marker

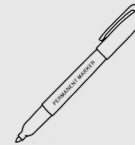

*Use a gold or silver marker to increase visibility when marking on black materials.

5. End Panels



6. Filler Panels

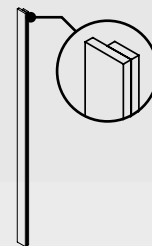

7. Flat Fillers



8. 28mm Screws
Countersink



*Each project may be different and will determine which panels/fillers are needed.

Miscellaneous

1. Floor Plans



2. Driver Bit to Suit Screws

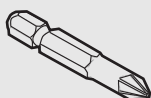

3. Drill Bit to Suit Screws



Seymour Install Guide

Step by Step

1.

Review architectural drawings and shop drawings to ensure the Seymour is installed in the correct location.

2.

When the Seymour is being delivered, have it placed as close to or at the install area. This will make this process easier and quicker.

3.

Place Seymour unit into position, ensuring that it is in the correct location. Be cautious of clearance at the top of the unit as the exhaust pipe protrudes 150mm at the top. Generally, the door should align with finished surfaces and/or other doors surrounding the unit.

If no doors are hung on the unit - set the carcass back 20mm from finished surface

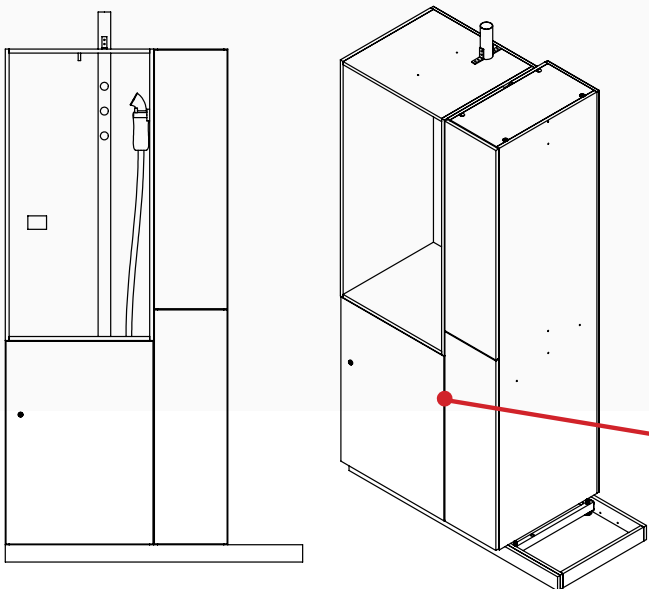
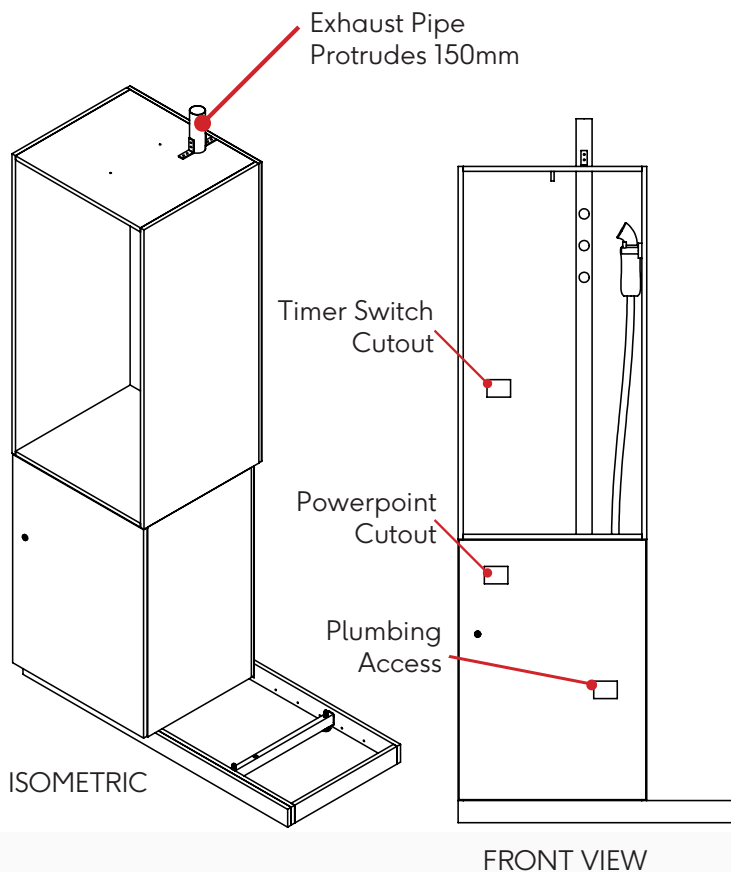

4.

As the Seymour is placed into position, pull electrical cabling through the timer switch cutout located in the upper unit and through the powerpoint cutout in the lower unit. Plumbing cutout underneath the pull out shelf in the lower unit should also align with water outlet.

5.

Once Seymour is in position and is aligned with all finished surfaces, open the lower cabinet and use a 40mm countersunk screw to secure the base and 30mm panhead screws to secure to adjacent units.

6.

Position the upper section flush with finished surfaces and from inside the lower cabinet, fix upward using 30mm panhead screws until secure.

If the Seymour is next to a wall and a scribe panel is needed, fit this to the upper section using 2no. 30mm panhead screws from the outside so that the screw does not penetrate the finished panel. Once upper section is secured to lower section, use 2no. 30mm panhead screws from the inside of the cabinet to complete fixing the scribe panel.



7.

Continue to the relevant steps based on your installation

End Panels

- Fasten to locker using a pre drill and 28mm countersunk screws. Two at the top (front and back), two at the bottom (front and Back) and one in the middle.
- If the lockers are against a wall, the panel should meet the wall with no gaps. It may be necessary to cut out for skirting at the bottom.
- Shoeboxes will be covered by a separate end panel
- Use screw caps to cover every screw head.

Filler Panels

- Measure the space between the locker-side and wall.
- Scribe a line onto the filler panel using the measurements and cut using a track saw or planer.
- Pre drill filler panel so it sits flush with the front door face and fasten to the 50mm blank backing piece using three 30mm panhead screws.
- Fix the backing piece to the locker using three 28mm countersunk screws.
- Use screw caps to cover screw heads.

Flat Fillers

- Measure from the ground to the top of the locker and cut flat filler to that height.
- Slide flat filler into position so it is sitting flush to the front of the doors and pre drill and fasten with three 28mm countersink screws.
- Use screw caps to cover screw heads.

Commissioning 1.

Connect the flexible hose from the inlet of the cistern to the cold water tap on the wall.

Ensure shutoff valve is in line with hose.

Ensure the non-return valve is in the default position.

Ensure power switch on the steamer appliance is "ON".

Open the electronic leak detection valve and insert 4 AA batteries supplied.

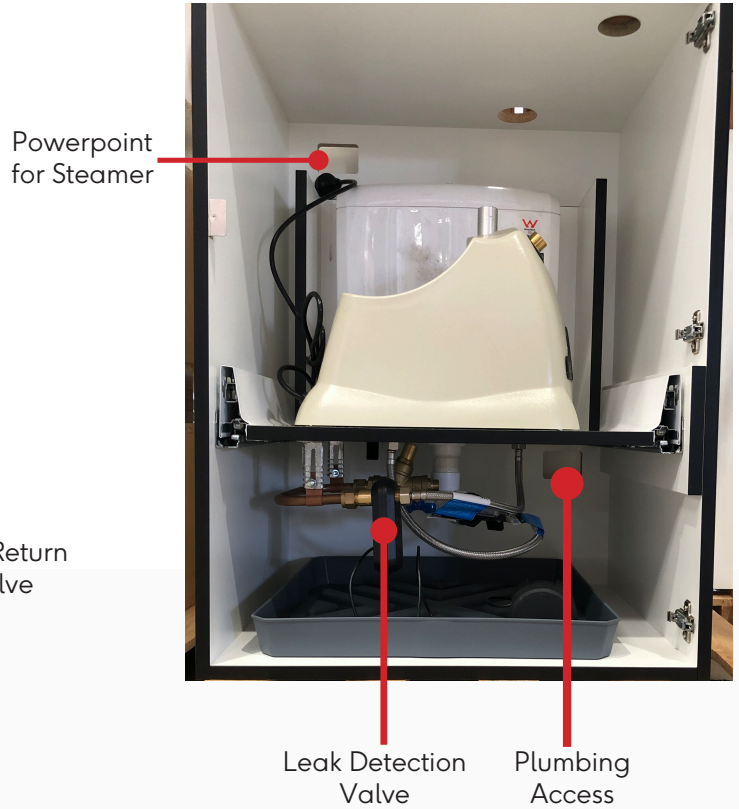
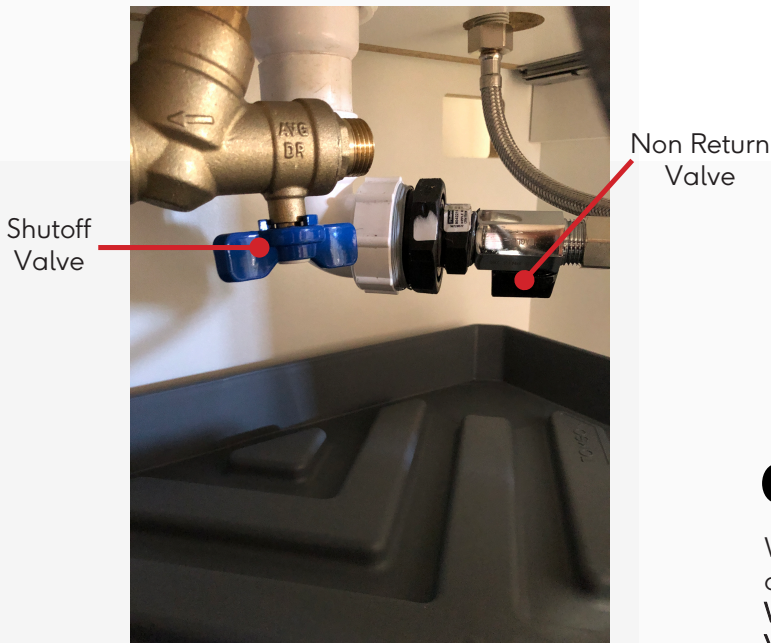

Commissioning 2.

When finished do a final check to make sure the flow of the plumbing is:

Wall Tap > Flexible Hose > Electronic Leak Detection Valve > Cistern > Non Return Valve > Flexible Hose > Steamer

When the water and power are active, the mini tap on the wall should be turned on. The unit will work when the timer switch is pressed.

Troubleshooting

If the unit does not produce steam?

This is almost always because either the power or water is not active. Please check this first.

If the steamer head is bubbling/spitting out water?

Restrict the flow of water from wall tap.

If no steam is coming out?

Check to make sure the water is turned on and all valves are in the open position. Also ensure power of the steamer is "ON".

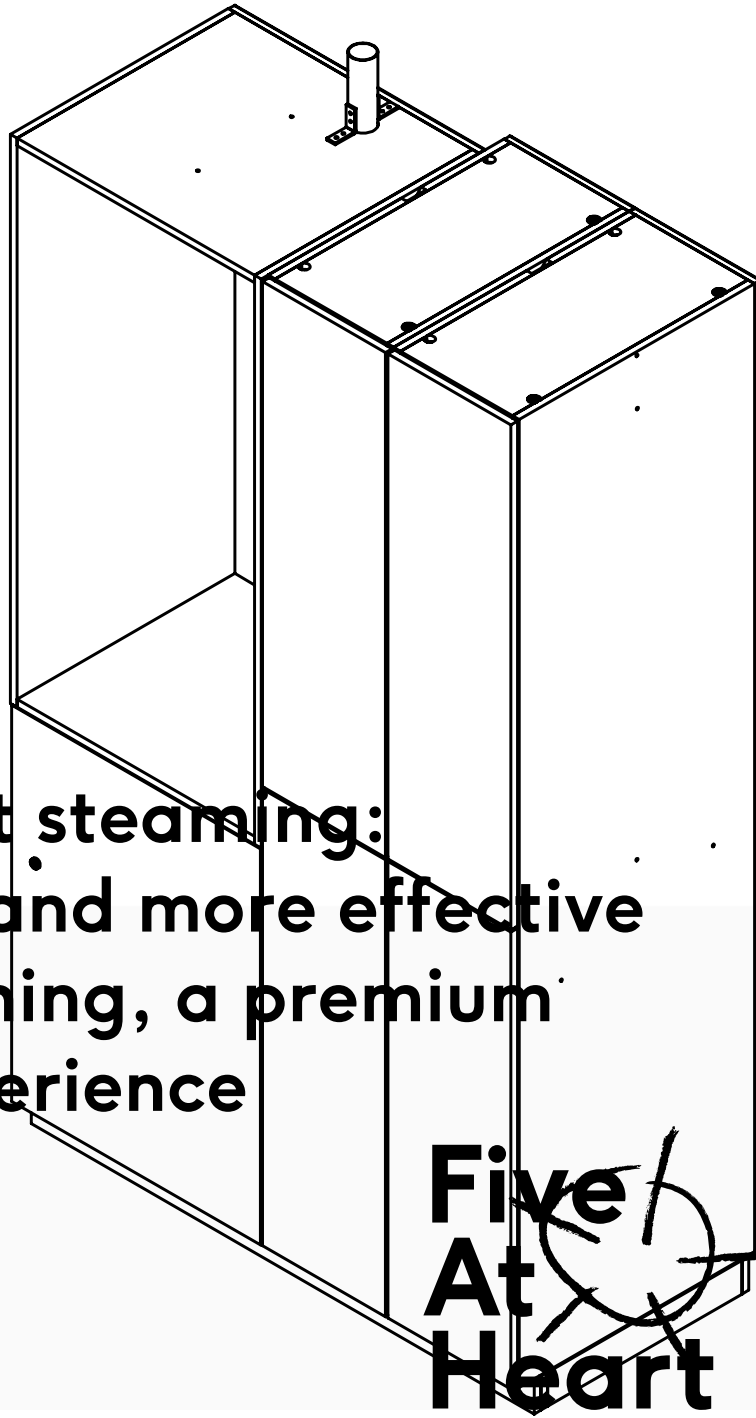

**Garment steaming:
quicker and more effective
than ironing, a premium
user experience**

**Five
At
Heart**