

# Halo



Spec Sheet

Five  
At  
Heart

# Brightens up any room.



**Five  
At  
Heart**

The logo for "Five At Heart" features the text "Five At Heart" in a bold, black, sans-serif font. To the right of the text is a stylized heart shape composed of a black circle with five red lines radiating from its center, resembling a pulse or a heartbeat.

# Halo.



Five At Heart

## Materials

40mm (1 37/64") plywood shelf

Copper plated hoops

Mild steel wall mounting bracket - powder coated black

## TOP VIEW

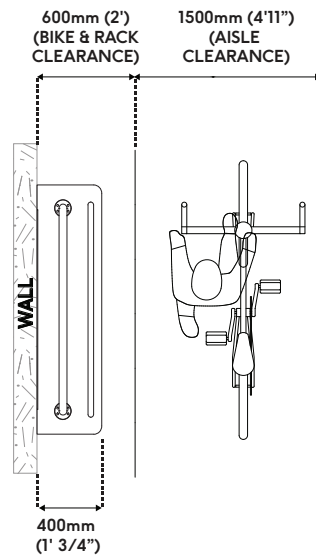

## SIDE VIEW

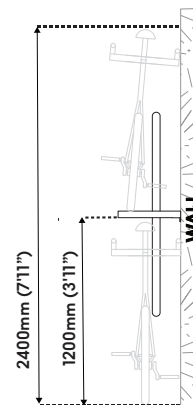

## FRONT VIEW

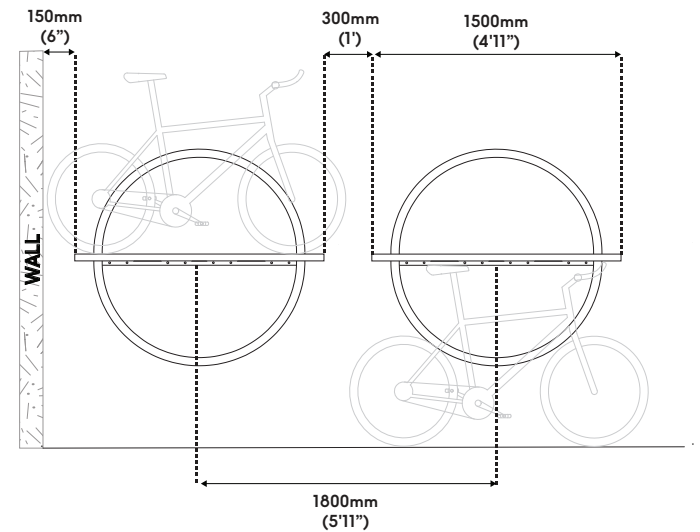

# Halo Warranty and Technical Data

## Warranty Information

Five At Heart's Halo comes with a standard 5 year warranty, effective from the handover date.

For the warranty period, we warrant that the equipment (and any materials) we supply will comply with the relevant standards at the date of installation.

This warranty is limited and may be excluded in part or in full in light of user damage or failure to install to Five At Heart specification.

We recommend a monthly visual inspection for signs of damage or need for cleaning.

Contact Five At Heart in the event of product damage.

## Disclaimer

Images may differ from actual product and specifications may change without prior notice.

Product is manufactured to metric dimensions.

## Fixing options/and details

**Fig 1** Into Concrete Wall – M10/50mm (1 15/16") zinc plated sleeve anchor

**Fig 2** Into Masonry Block work – Buglescrew and ram plug

**Fig 3** Dimensions for Mounting Halo on wall

## Product weight

40 kg

## Substrate requirements

- Concrete – 100mm (3 15/16") thick and in good condition
- Masonry Block

## Maintenance Requirements

If any moving parts appear to be malfunctioning, discontinue use and contact Five At Heart.

## Cleaning

Cleaning should start at the time the products are installed, ensuring that construction materials such as concrete, plaster and paint splashes are removed before they have a chance to dry. Failure to remove these materials will require aggressive cleaning in the future, that may be harmful to the products.

Wipe with a damp cloth for surface cleaning. Regular cleaning may be done with a solution of warm water and a non-abrasive, pH neutral detergent solution. Surfaces should be thoroughly rinsed after cleaning to remove all residues.

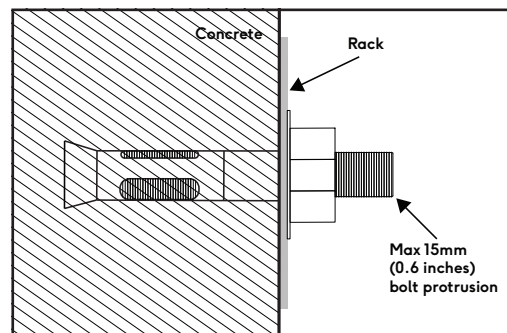

**Fig 1** Concrete Wall

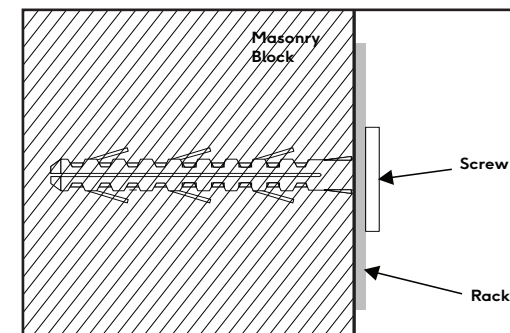

**Fig 2** Masonry Block

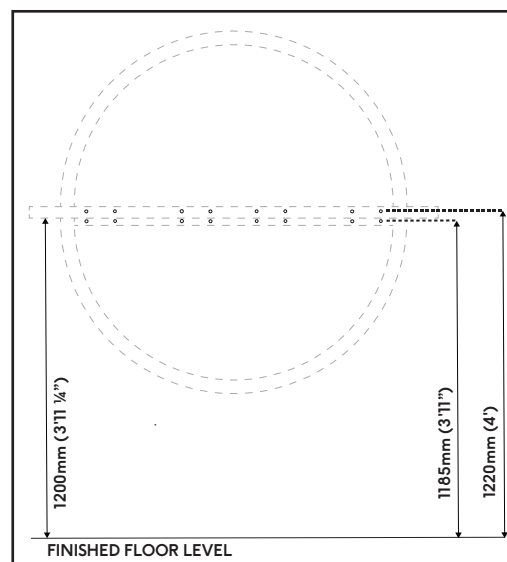

**Fig 3** Mounting Heights

**WARNING:** DO NOT UNDER ANY CIRCUMSTANCES USE STRONG SOLVENTS SUCH AS THINNERS OR SOLUTIONS CONTAINING CHLORINATED HYDROCARBONS, ESTERS OR KETONES. ABRASIVE CLEANERS OR CUTTING COMPOUNDS SHOULD NOT BE USED.

# Five At Heart



Creating  
spaces  
for however  
you Roll...



[fiveatheart.com](http://fiveatheart.com)

**Australia**

(+61) 1300 769 332 or [au\\_info@fiveatheart.com](mailto:au_info@fiveatheart.com)

**North America**

(+1) 888 218 3433 or [na\\_info@fiveatheart.com](mailto:na_info@fiveatheart.com)

**Europe**

+44 (0)20 3137 1966 or [eu\\_info@fiveatheart.com](mailto:eu_info@fiveatheart.com)