

Iron Maiden.



Spec Sheet



Official Patent and Design Numbers (either pending or granted)
Australian patent no. 2019900523 | Great Britain design no. 6073090

The first Ironing Station specifically designed for the heavy duty needs of commercial change rooms.



**Five
At
Heart**

Iron Maiden.



Iron Maiden

Five At Heart

Material

Laminated MDF door (AUS: E0 MR)
(with extensive colour range)

White particleboard carcass (AUS: E1 MR)

Moisture resistant base with black finish

Steel ironing board

Specification

(Z) Bulk head or 30 degree slope top
(Optional)

Iron included

2x Ironing board covers

Powerpoint and timer switch supplied
Electrician needs to install and wire onsite
(done by others)

TOP VIEW

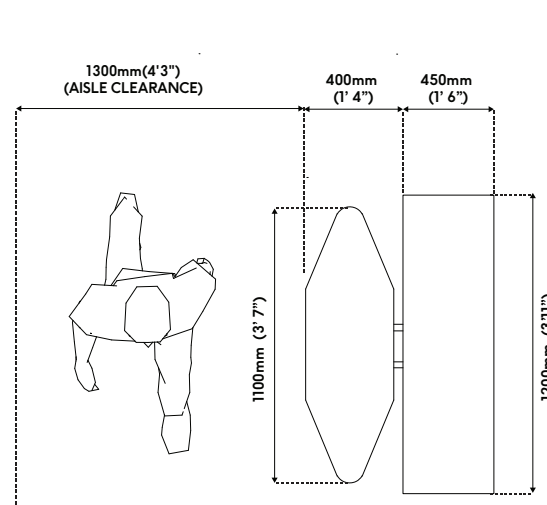

SIDE VIEW

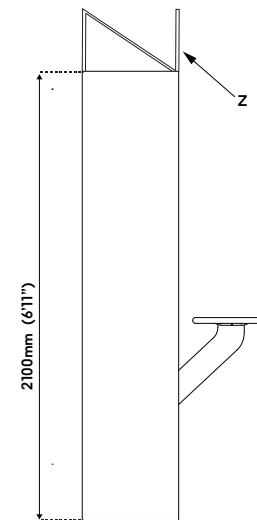

FRONT VIEW

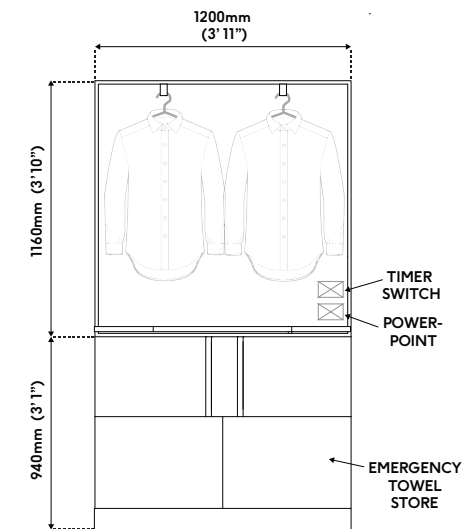

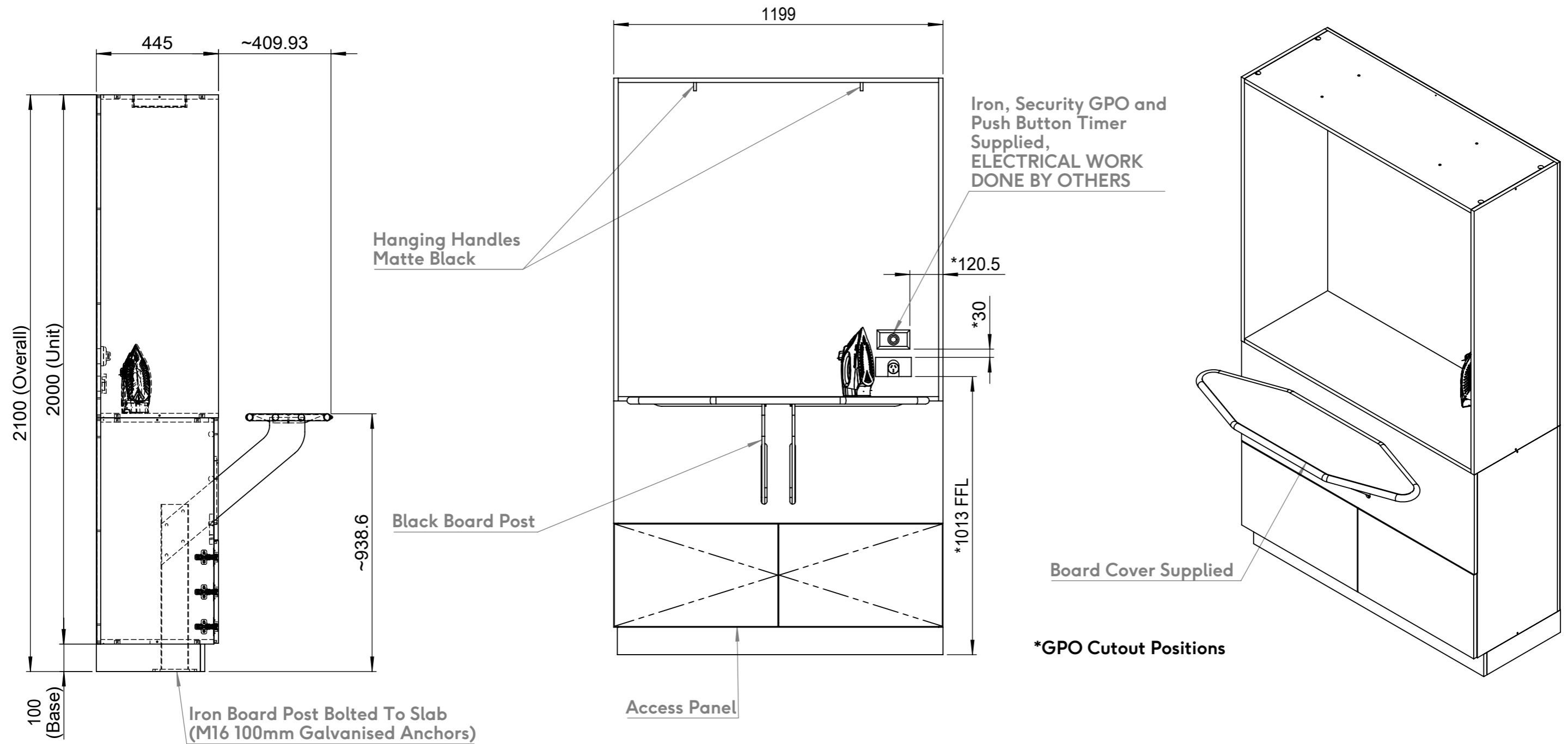

CIRCULAR PRODUCT

CARCASS IS PRE-MADE (NO MODIFICATION)
PLEASE CONFIRM COLOUR

Item	Item Description
Hanging Handles	Matte Black
Iron	Phillips GC3929/64
Door & Panel Colour	
Carcass	16mm White MR Particleboard
Base Front Colour	
Door Edging	1 mm ABS Matching
Carcass Edging	1 mm ABS Black



Iron Maiden Full

Project

SHEET 1 of 1

P- -DWG- REV 1 SCALE: 1:15

DATE:	REV:	DWN:	CHK:	DESCR:

Iron Maiden. (Trim)



Iron Maiden

Five At Heart

Material

Laminated MDF door (AUS: E0 MR)
(with extensive colour range)

White particleboard carcass (AUS: E1 MR)

Moisture resistant base with black finish

Steel ironing board

Specification

Iron included

2x Ironing board covers

Powerpoint and timer switch supplied
Electrician needs to install and wire onsite
(done by others)

TOP VIEW

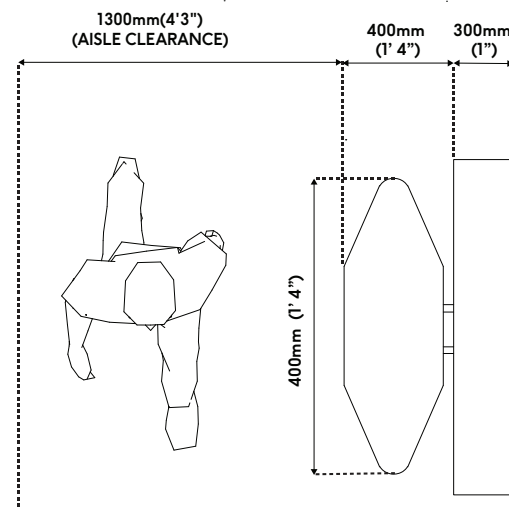

SIDE VIEW

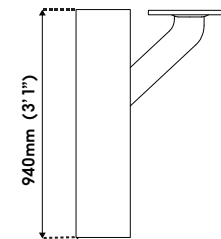

FRONT VIEW

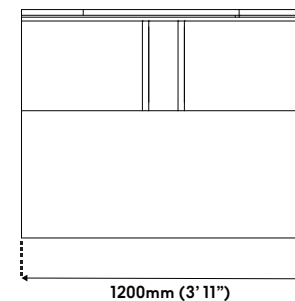

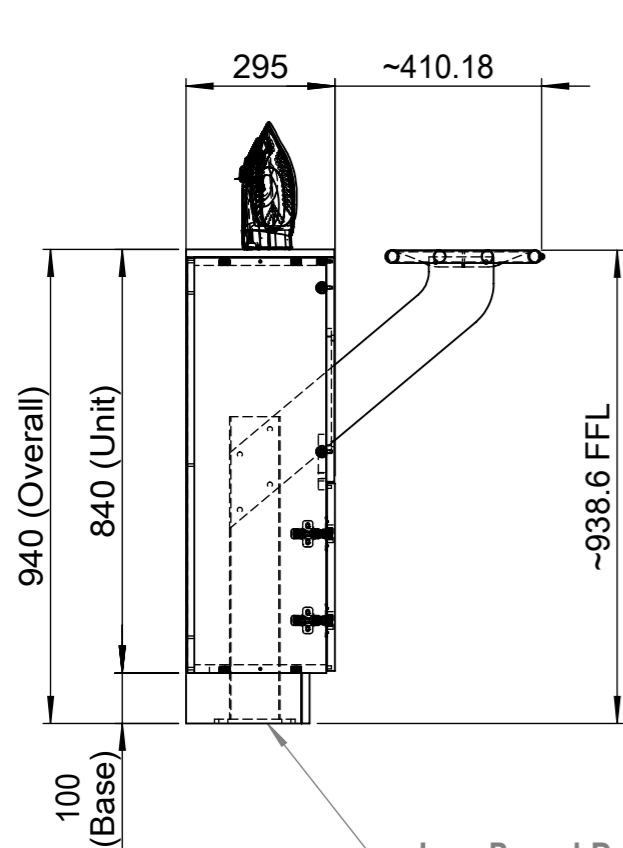

Iron Board Post Bolted To Slab
(M16 100mm Galvanised Anchors)

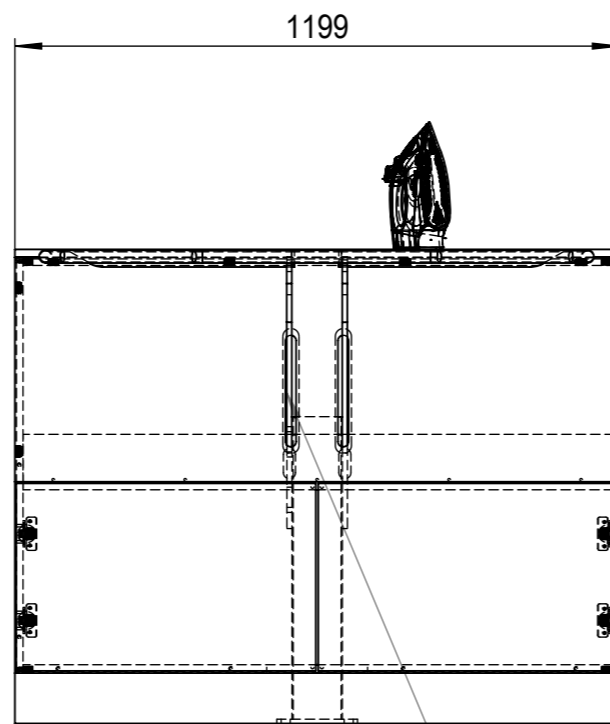

Black Powder Coated Board Post

Iron, Security Power
Point and Push Button
Timer Supplied,
ELECTRICAL WORK
DONE BY OTHERS

Board Cover Supplied

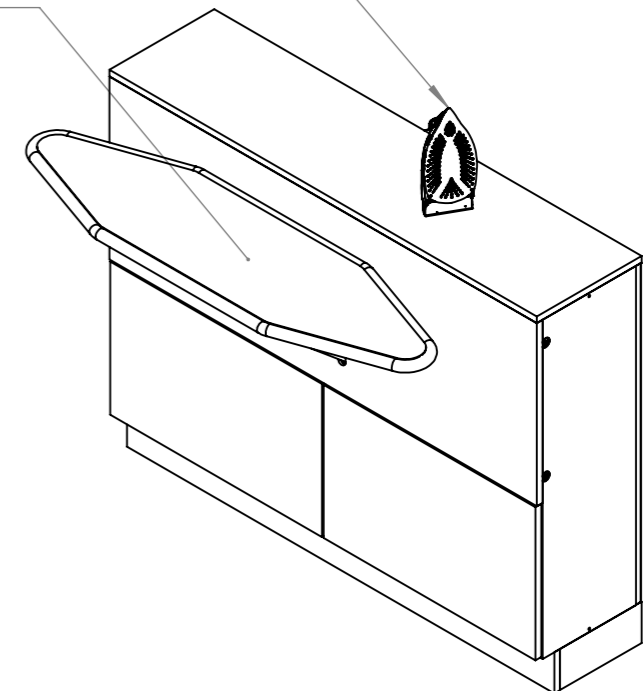

CIRCULAR PRODUCT

CARCASS IS PRE-MADE (NO MODIFICATION)
PLEASE CONFIRM COLOUR

Item	Item Description
Iron	Phillips GC3929/64
Door & Panel Colour	
Locker Carcass	16mm White MR Particleboard
Base Front Colour	
Door Edging	1 mm ABS Matching
Carcass Edging	1 mm ABS Black



Iron Maiden Trim

Project:	SHEET 1 of 1
P-	-DWG- REV 1 SCALE: 1:15

DATE:	REV:	DWN:	CHK:	DESCR:

Ironing Station Warranty and Technical Data

Warranty Information

Five At Heart's Iron Maiden comes with a standard 7 year warranty, effective from the hand over date.

For the warranty period, we warrant that the equipment (and any materials) we supply will comply with the relevant standards at the date of installation.

This warranty is limited and may be excluded in part or in full in light of user damage or failure to install to Five At Heart specification.

We recommend a monthly visual inspection for signs of damage or need for cleaning.

Contact Five At Heart in the event of product damage. Iron subject to manufacturer warranty.

Disclaimer

Images may differ from actual product and specifications may change without prior notice. Five At Heart is not liable for the structural integrity of the substrate and any queries should be directed through the project engineer.

AUS, UK, CAN: manufactured to metric dimensions.

USA: manufactured to imperial dimensions.

Fixing options and details for Ironing board

Fig 1 M16/95mm (25/64" x 3 47/64") galvanised sleeve anchor

Substrate requirements

- Concrete - 160mm (6 19/64") thick and in good condition

Power Requirements

Standard AC power supply required for powerpoint and 10 minute timer switch. Cut outs in joinery and hardware supplied (Powerpoint and timer switch). An electrician will need to install and wire onsite (done by others)

Fig 2 shows the rough in detail for powerpoint and timer switch.

Installation Requirements

Lockers/auxiliary units require a minimum of 16mm (5/8") at the end of each nib wall for filler panels and 50mm (2") for corner fillers.

Base plate and fixing nuts must be sealed to the substrate using Sikaflex Pro+ Polyurethane Sealant or equivalent.

Maintenance Requirements

If any moving parts appear to be malfunctioning, discontinue use and contact Five At Heart.

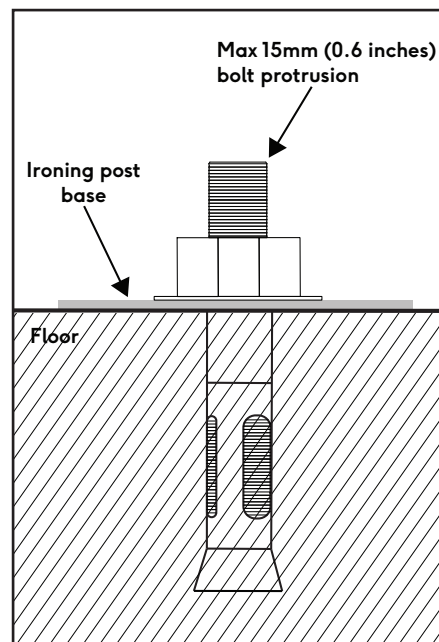

Fig 1 M16/95mm (25/64" x 3 47/64") galvanised sleeve anchor

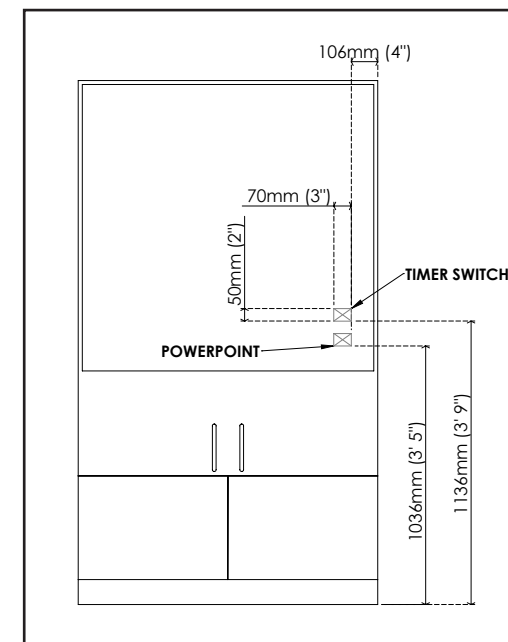

Fig 2 Electrical rough in details

Cleaning

For general care and maintenance, simply wipe away most spills or marks with a damp cloth, or wipe clean with non abrasive household cleaner.

Do not submerge product at any point.

Avoid scourers and abrasives as they will damage the surface.

Do not use waxes or polishing products as they dull the natural shine. Contact Five At Heart for replacement ironing board covers.



CAUTION:

Iron will be hot during operation and for a period of time after operation.

Five At Heart



Creating
spaces
for however
you Roll...



fiveatheart.com

Australia

1300 769 332 or au_info@fiveatheart.com

North America

1888 218 3433 or na_info@fiveatheart.com

Europe

(+44) 20313 71966 or eu_info@fiveatheart.com